

The UCP1B proximity probe is a lightweight and versatile instrument specifically designed to carry out underwater cathodic protection potential measurements



FEATURES

- Hard-wearing DELRIN body
- Half Cell can be replaced
- Lightweight design
- Easy to use
- Suitable for fitting to manipulator arm

TECHNICAL SPECIFICATIONS

Half Cell

- Type: Silver/silver chloride screw-in
- Output: $\approx +250\text{mV VS SHE}$
- Temperature coeff: $-0.6\text{mV per }^{\circ}\text{C}$
- Temperature range: $0 - 30^{\circ}\text{C}$
- Working life: 1 to 2 years

Unit

- Designed for use with remote voltmeter
- Minimum load impedance $> 10\text{M Ohms}$
- Weight: 0.5Kg
- Size: $126\text{mm} \times 39\text{mm}$ diameter
- Packed weight (complete): 0.8kg
- Dimensions (packed): $26\text{cm} \times 14\text{cm} \times 30\text{cm}$

UNDERWATER CABLE LENGTH VARIATIONS

- 3m long x 9mm: 6004-0043
- 50m long x 9mm: 6004-0102
- 100m long x 9mm: 6004-0103
- 200m long x 9mm: 6004-0104
- 300m long x 9mm: 6004-0105
- Free issue whip: 6004-0050

Note: Due to ongoing technical developments, all stated information is typical and is subject to change without notice or obligation.

The probe has been developed for use with manned or Remotely Operated Vehicles (ROVs) and comes complete with differing lengths of underwater cable. Each probe is supplied with a Certificate of Inspection and Conformity.

By placing the UCP1B in close proximity to the surface under test, a voltage reading can be obtained on a suitable high impedance or digital voltmeter. The meter should be connected between the probe and a separate structure negative return.

The UCP1B is extensively used in a wide range of applications including production and drilling platforms, ships' hulls, jetties and other marine works.

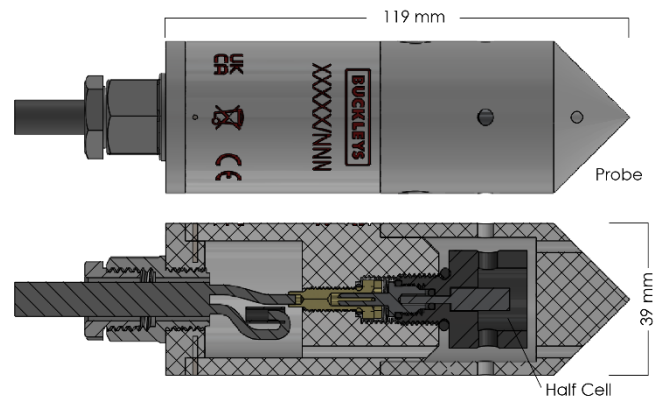

ANCILLIARY PRODUCTS AVAILABLE



Silver/Silver Chloride
Half Cell
6004-0051



Calibration Kit
6004-0032



Glass K-Series
Reference Cell
6004-0013

AFTER SALES SERVICE / TECHNICAL SUPPORT

All Buckleys products are manufactured under the controls established by a quality management system that meets the requirements of BS EN ISO 9001:2015 and are supplied with a one year 'back-to-base' warranty. The equipment is proven to be robust and reliable and will give years of service if maintained in accordance with our instructions.

Buckleys provide full repair and calibration facilities; offering a fast turn-around service for customers' equipment.

Advice on specific applications for all Buckleys products is available from our technical department. Contact us by telephoning, sending a fax or by e-mail using the contact details below.

Buckleys (UVRAL) Ltd.

Buckleys House, Unit G, Concept Court, Shearway Business Park, Shearway Road, Folkestone, Kent. CT19 4RG. UK

Tel: +44 (0)1303 278888

Fax: +44 (0)1303 274331

Email: sales@buckleys.co.uk

Website: www.buckleysinternational.com